

Handheld Force Measuring System

masterforce[®]
The Art of Precision



KAM



KAP-S



KAF-W



KAN-G



Applications

- Industrial automation
- Machine testing
- System calibration

Features

- Portable and ready to use
- Fast setup through built-in sensor recognition and multipoint calibration (TEDS-M)
- High accuracy through calibrate the complete measurement chain
- Traceable calibration certificate, optionally DAkkS calibration certificate
- Industrial quality
- Data-logging with PC-software (included)

The force measurement system **masterforce**[®] is very easy to use and useful for testing or calibrating machines and installation equipped. This helps to comply with quality regulations, i.e. ISO 9001. The instrument provides an USB-interface to our PC- software **ASTAS**[®] which allows additional programming and multipoint calibration of the sensor. The software also features a data logging to PC function which stores up to 1600 values per second directly into a Microsoft-Excel file. The **masterforce**[®] system can be extended by an infinite number of other strain gauge sensors. With AST's TEDS function every sensor is recognized with its nominal value and calibration data. The stable transportation case contains the instrument, sensor, USB-cable, CD-ROM with software and documentation and a printed documentation. Software and manual are in English and German language. Our factory calibration as well as the optionally according to ISO 376 calibration includes the calibration for tension and compression for our bi-directional force sensors. The new **masterforce**[®] is a measurement kit containing one of the most accurate handheld force measurement instruments on the market, a calibrated force transducer to measure loads with TEDS-M function and our PC software **ASTAS**[®].

The integrated TEDS-M function makes the setup very fast and easy: The sensor data are stored in a chip that is part of the sensor plug. The data contain information such as:

- Rated load and up to 5 calibration points
- Sensitivity
- Name of the sensor
- Manufacturer
- Date of calibration

Cable length 1.5m (KAF-W and KAN/KAN-G: 3m)

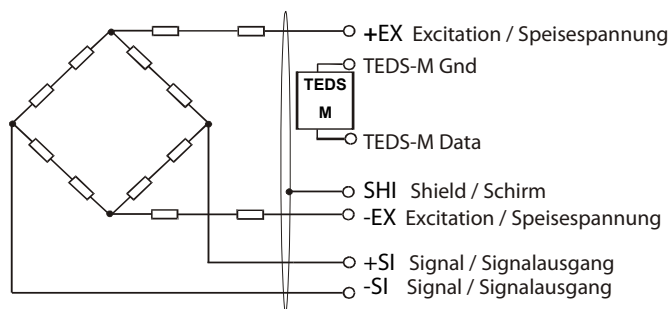

Specifications with typical sensors

Sensor		KAM	KAP-S	KAF-W	KAN-G
Accuracy class	% F_{nom}	0.1	0.05	0.05	0.5
Rated (nominal) force (F_{nom}) compression	kN	0.1 ... 200			500 ... 3000
Rated (nominal) force (F_{nom}) Compression and tension	kN		0.05 ... 50	0.2 ... 10	
Reference temperature (T_{ref})	°C	+23	+23	+23	+23
Rated temperature range ($B_{T,nom}$)	°C	-20 ... +60	-20 ... +60	-20 ... +60	-20 ... +60
Maximum operating force (F_G)	% F_{nom}	150	150	150	100
Breaking force (F_B)	% F_{nom}	300	300	300	300
Lateral force limit (F_Q)	% F_{nom}	50	10	100	20
Environmental protection (EN 60529)		IP 67	IP 42	IP 54	IP 67
Instrument					
Input signal range (C_{nom})	mV/V			0.3 ... 5	
Sensor supply voltage	VDC			5	
Internal resolution at 2 mV/V	Bit			22	
Sampling rate (averaging)	Hz			6.25 ... 1600	
Relative linearity error (d_{lin})	%			0.0015	
Noise (at sampling rate)	% F_{nom}			0.002 (6.25 Hz) ... 0.04 (1600 Hz)	
Display				5 digit LCD, 14mm	
Display refresh rate	1/s			3	
Display refresh rate (PC)	1/s			6	
Display modes				measured/max./ min./overload/various units/battery	
Display increments				0.1N / 0.01kg (0.1 ... 1kN) 0.001kN / 0.1kg (2 ... 20kN) 0.01kN / 1kg (50 ... 20kN) 0.1kN / 0.01t (500kN) 1kN / 0.1t (1 ... 3MN)	
Data logging function, measure rate (PC)	Hz			up to 1600	
USB Interface				Mini USB-B	
Reference temperature (T_{ref})	°C			+23	
Operating temperature range ($B_{T,G}$)	°C			-10 ... +50	
Storage temperature range ($B_{T,S}$)	°C			-30 ... +70	
Environmental protection (EN 60529)				IP 54	

All data according to VDI/VDE/DKD 2638

Order Example

Type Code	Description
MasterForce/KAP-S/1kN	Handheld instrument MasterForce with TEDES-M KAP-S force transducer 1kN Rated (nominal) force of sensor Sensor type (KAP-S = compressive and tensile, KAM = compressive loads) All Sensors come with factory calibration at nominal force, case, software and manual. At least one AE 703 must have Masterforce® System configuration
Option XKD 221	ISO 376 calibration compression
Option XKD 222	ISO 376 calibration for tension
Option XKD 223	ISO 376 calibration for compression and tension